

Model 3139/15



Featuring patented vacuumized drum



3139/15 Wipe-On

Primary Applicator

Have a Label-Aire Authorized Distributor
contact you. Visit www.label-aire.com.



3139/15 Wipe-On Specifications

The Label-Aire® Model 3139/15 Label Applicator works very hard so you don't have to.

The Model 3139/15 Label Applicator applies labels around any corner or two labels on adjacent panels utilizing our patented vacuumized drum.

Pre-printed labels are applied utilizing the Model 3115 as the label dispenser. The 3139/15's sturdy swing arm can be configured for cartons or pallets. The heavy duty square-frame mounting stand can be bolted to the floor for added stability. Like all Label-Aire products, the 3139/15 Label Applicator is built to meticulous quality standards and designed to withstand the most intense operation.

Put this advanced workhorse label applicator to work for you. The Model 3139/15 Label Applicator is designed to run seamlessly in your operation, saving you money in the long run.

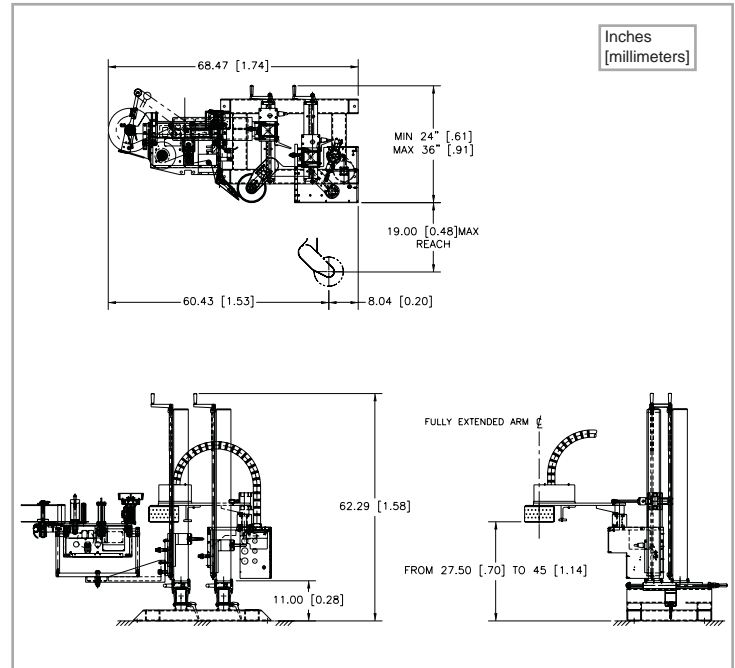

3139/15 Wipe-On Advanced Features	
Automatic setup	Includes multiple programmable label pages for easy change-overs to different label sizes.
R3 digital display	With five languages (English, French, German, Italian, Spanish) and detailed alarm message.
Quick-Action collapsible rewind	For easy removal of scrap liner.
Optional powered rewind	For improved label accuracy and dynamic web tension control.

Dimensions:

Height: 62.29" (1.58 m)
 Length: 68.47" (1.74 m)
 Width: 24" (.61 m) Min. (Max. width dependent upon arm length.)

Weight:

Approx. 500 lbs. (227 kg)

Standard Label Dimensions:

Label Width: Up to 8.8" (224 mm)
 Label Length: Up to 24" (610 mm)

Dispense Speed:

Up to 1,500' (38.1 m) of web per minute

Label Placement Accuracy:

Up to +/- 1/8" (.125 mm)

Electrical:

115 Volts AC 60 Hz 5 Amps.
 220 Volts AC 50 Hz

Air (as needed):

4 cfm at 90 psi for most applications

Options:

Wide range of arm lengths
 RFID configurable
Consult factory for additional options.



Headquarters
 550 Burning Tree Road
 Fullerton, CA 92833 USA

o 714.441.0700
 f 714.526.0300
 e info@label-aire.com
 w www.label-aire.com

Europe
 Sjællandsvej 27A
 DK-9500 Hobro, Denmark

o +45.9657.0063
 f +45.9657.0064
 e info@label-aire.com
 w www.label-aire.com

Asia
 No. 10, Lane 228, Taisi S. Road
 Longjing Township
 Taichung County 434, Taiwan

o +886.4.2395.5684
 f +886.4.2395.8007
 e info@label-aire.com

Distributed by:

Westmark Industries, Inc.
 6701 SW McEwan Road
 Lake Oswego, OR 97035-7815
 Phone: 1-800-275-2228
 Fax: 1-800-303-7491
 www.westmarkind.com