

CVC302 High Speed Wrap Labeler

- Lower Operating Costs

- Increase Operating Flexibility

- Unparalleled Service

- Quality that your Customers Demand



• Lot/ Date Inspection



• Reject Station



• Bar Code Inspection



The CVC302 High Speed Wrap Labeler is built to automatically apply *pressure sensitive* labels onto round containers at up to 200 bottles per minute. The 302 is *servo motor* controlled, comes standard with a touch screen HMI, and can be ordered with various inspection options including bar code verification, vision, and missing label detection. The 302 is an ideal machine for contract packagers and manufacturers serving the pharmaceutical, nutraceutical, and food markets. The 302 can run stand alone or integrated into a full packaging line.

All CVC labelers include our patented **Self Set™** software which utilizes a high frequency encoder for extremely easy setup and wrinkle free labeling at the touch of a button.

Labelers

Solid Dose Bottling Lines
Blister Packaging
Cartoning

"Leading Global Equipment Supplier"

www.cvcusa.com



CVC Technologies, Inc.

CVC302 Technical Specifications

Standard Features:

- Self Set Auto Adjusting Control System
- Stainless Steel Frame on lockable casters
- Stainless Steel sanitary bed conveyor with 4" wide ground down table top chain.
- Touchscreen HMI programmable in English, Spanish, and Chinese
- Label head with up to $\pm 1/32$ " accuracy and Integrated Wrap Station
- Servo motor with Panasonic PLC controls
- Adjustable Tilt for Tapered Bottles
- Label Sensor for Paper or Opaque Labels
- Product Sensor with Opaque and Clear Bottle Mode
- Variable Speed Separator Wheel
- Capacity up to 250 bottles per minute (BPM)
- ISO 9001:2000 Certified

Container Specifications:

- Bottle Height: 1" up to 12" (25mm - 305mm)
- Bottle Diameter: 1" to 7" (25mm - 178mm)
(dependent on conveyor width)

Label Specifications:

- Label Width/Height: 3/8" to 7" (10mm - 178mm) (dependent on labeling head type)
- Label Length: 1/2" to 12" (13mm - 305mm)
- Label Roll: max 16" (356mm) outside diameter with 3" core
- Label Head Dispense Speed: Maximum 75 Meters/Min.

Machine Specifications:

- Conveyor Width: Standard 4", available in 4-1/2", 6"
- Conveyor Length: Standard 79", available in 94" and 108"
- Conveyor Bed Height: Standard 36" (± 2 ")
- Machine Weight: 350kg

Air/Electrical Requirements:

- Power: 220V, Single Phase, 6 AMP
- Air Pressure: 85psi (for Optional Reject and Lot/Date Printer)
- Air Consumption: 4 cfm (for Optional Reject and Lot/Date Printer)



Quality • Value • Service

Authorized CVC Dealer

Copyright © CVC Technologies, Inc. • Jan. 2012 Edition

Available Options:

Printing:

- Hot Stamp (Lot/Date Coding)
Print Area: 2-3/4"(70mm)W x 2-1/2"(65mm)H
Type Sizes: 1.5mm, 2.0mm, or 2.5mm
Chase Size: 6 Lines of 13-22 Characters each
Low Ribbon Sensor
- Integrated Thermal Encoder (Lot/Date, Bar Code and Graphics)

Assemblies:

- Bottle Rejection System (Air Blow or Cylinder)
- Laser Bar Code Verification
- Spot and OCV Vision for Lot/Date Code Inspection
- Missing Label Detection System (UV)
- Feed Screw
- Loading and Collecting Turn Tables
- Infeed and Outfeed Conveyor Extensions
- Custom Wrap Belts
- Clear Label Sensor
- Low Label Sensor (Factory Installed Only)

Machine Layouts:

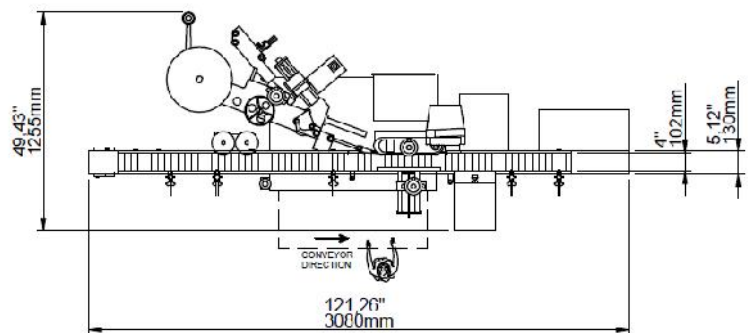

Top View

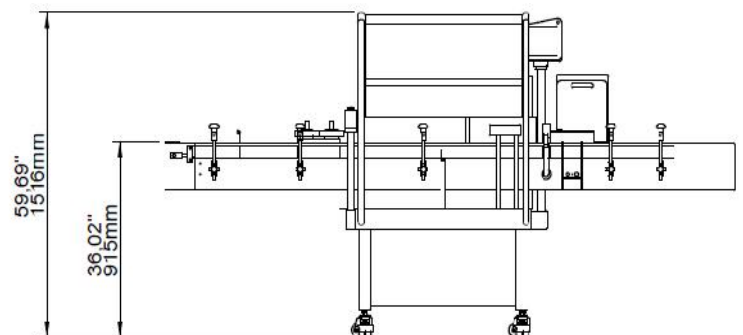

Front View

Dimensions shown are for standard machine. Conveyor can be extended or length may vary based on options selected. This labeler can run independently or be integrated into an automated packaging line.